

Design of Sparse Uniform Linear Array Beamformer using Modified FRM Structure for Varied Applications

Original Scientific Paper

Parvathi Ammothum Kandy

Department of Electronics and Communication Engineering, National Institute of Technology Calicut
Kerala, India
parvathi_p180072ec@nitc.ac.in

Sakthivel Vellaisamy

Faculty of Department of Electronics and Communication Engineering, National Institute of Technology Calicut, Kerala, India
sakthi517@nitc.ac.in

Abstract – This paper presents a method to generate antenna patterns for a Uniform Linear Array (ULA) having narrow beamwidth and low sidelobe levels (SLL) using the recently proposed Modified FRM (ModFRM) architecture. This allows it to direct the beams to specific ground cells for communications while mitigating inter-cell interference. The sharpness of the beam pattern defines the spatial discriminating performance of a ULA beamformer, while the SLL dictates the interference and noise suppression capabilities. Typically, a conventional ULA beamforming will demand high computational complexity and a large number of sensors to satisfy these requirements. Hence to reduce the system cost, using the ModFRM technique a sparse array is developed. With this strategy, the total number of sensors is drastically reduced compared to conventional ULA beamformers. The designed beamformers can be used in applications with stringent requirements where cost and size are concerned.

Keywords: Spatial filtering, Beamformer, Uniform Linear Array (ULA), Frequency response masking (FRM), Spatial interpolation

1. INTRODUCTION

Beamforming is one of the most common forms of distinguishing different signals depending on their physical location. Communication, sonar, radar, medical diagnostics, seismology, and speech acquisition for teleconferencing are just a few examples of real-world applications [1-3]. It is primarily used to identify the existence of the desired signal by filtering both interference and noise signals. These requirements necessitate beamformers with sharp beams having low sidelobes. Tapered beamformers in [4] can fulfill these criteria, but only with a trade-off between a narrow beam and a low sidelobe level (SLL). Furthermore, specifying the main beamwidth and SLL requirements is problematic for tapered beamformers.

A beamformer can be considered a spatial filter that processes sensor array outputs to generate the required beam (directivity) pattern [2]. Two sub-processes make up a spatial filtering operation: synchronization and weight-and-sum. Although both processes are essential in controlling the array beam pattern (the synchronization part governs the steering direction

and the weight-and-sum process governs the main lobe beamwidth and sidelobe characteristics), the second step is given more attention.

Among the various techniques, array beamformer synthesis is closely associated with the design of digital finite-impulse-response (FIR) filters, in which the tapped delay line is transformed by spatial delay, and the filter length is proportional to the number of antennas. The Uniform Linear Array (ULA) is the most widely used array geometry because of its simplicity, superior directivity, and realization of the narrow beamwidth in a given direction [5,6]. In the ULA beamformer, the spatially sampled sequences from each sensor are linearly combined in the same way the temporally sampled data are linearly combined by an FIR filter [7]. It is well known that the passband and stopband ripples, as well as the transition bandwidth, are the crucial aspects of a typical FIR filter design problem. Likewise, the most significant beam pattern characteristics are main beamwidth, SLL, and null-to-null beamwidth. A narrow transition width and low sidelobes beamformer are desirable as the sharp transition impacts the spatial discriminating performance, and the SLL determines the

interference and noise removal capability. However, designing an appropriate beam pattern with narrow transition bands and minimal sidelobes using traditional FIR filter design approaches such as windowing methods would require many sensors, resulting in high cost and high computational complexities. Hence, the objective is to achieve this with the fewest sensors possible.

Sparse array models distribute sensors optimally, thus obtaining desired beamforming attributes while lowering overall hardware costs and simplifying data processing. There-forth, sparse arrays have received much attention from system designers to save costs [8-12]. In sparse array beamforming, interpolation techniques are frequently used [5,13-15]. FIR filter design techniques, such as Frequency response masking (FRM) proposed by Lim [16,17] and interpolated FIR [18], have lately been investigated to see if they may be used in array processing [19-21]. Rosen et al. [22] recently proposed beamformers with constant beamwidths based on FIR. The primary idea behind this method is to adjust the effective array aperture to keep the beamwidth constant over the specified frequency band. Although this method has reduced computational complexity, it cannot modify the sidelobe level.

This paper presents a framework for designing active sparse linear arrays useful for radar/sonar applications using Modified FRM (MoFRM) approach proposed in [23]. This approach designs a pencil beam pattern with a specified maximum SLL which allows it to discriminate between two objects in proximity and avoid inter-cell interference. Owing to the low computational cost and ease of implementation, this technology is well suited for real-time digital beamforming scenarios such as satellite and high-altitude platform systems that need many array components.

The following is an overview of the structuring of this paper. Section 2 provides a brief overview of the analogy between the ULA and the FIR filter. The ModFRM approach for array pattern design is discussed elaborately in Section 3. The design of the desired antenna radiation pattern and the proposal outcomes are presented in Section 4. Section 5 brings the paper to a close-by reviewing the benefits of the proposed ModFRM beamformer and outlining future research prospects.

2. ANALOGY BETWEEN ULA BEAMFORMING AND FIR FILTER

Beamforming is a method that confines a signal on a specific receiving device as opposed to having it spread out in all directions and also attenuating signals from other locations [24,25]. In the cases, when the desired signal and interference are from the same frequency band, temporal filtering is typically ineffective in separating the two. However, the targeted and undesired signals are usually generated from different spatial points. Using a spatial filter at the receiver,

this spatial separation may be used to isolate the desired signal from other interference. In the same way, as temporal filter processes the data acquired across a temporal range, spatial filter processes data gathered over a spatial aperture. The magnitude response of an FIR filter is analogous to the beam pattern of an antenna array. Likewise, the sine of the direction of arrival (DOA), $\sin \theta$, and the temporal frequency f_i of the FIR filter input have an analogy. The DOA refers to the general direction from which a wave that is propagating typically arrives at a region where typically a group of sensors are placed [26,27]. As ULA and the FIR filter have a correspondence, a theorem that applies to the FIR filter in the time domain will also apply to the ULA in the space domain.

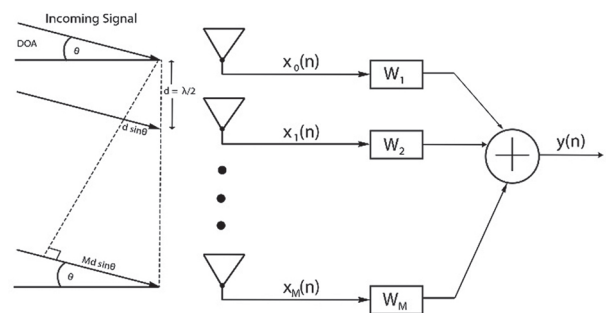

Fig. 1. Narrowband beamformer using ULA.

The frequency response of an N^{th} order FIR filter with impulse response $h(n)$ to a signal of frequency ω is,

$$H(\omega) = \sum_{n=0}^{N-1} h(n)e^{-j\omega n} \quad (1)$$

The beamformer response for an N-sensor beamformer with an aperture function $b(n)$ is,

$$B(\theta, \omega) = \sum_{n=0}^{N-1} b(n)e^{-j\omega t_n(\theta)} \quad (2)$$

where $t_n(\theta), 0 \leq n \leq N - 1$ is the propagation delay concerning the first sensor. In a nutshell, the sine of the direction in a narrowband, linear equi-spaced beamformer is the same as the temporal frequency in a FIR filter.

From the classical ULA beamformer depicted in Fig. 1, its resemblance with the FIR filter can be better understood.

3. PROPOSED SPARSE ULA BEAMFORMER USING MODIFIED FRM STRUCTURE

3.1 MODIFIED FRM STRUCTURE

Fig. 2 is the layout of designing a ModFRM filter. A prototype filter, $H_a(z)$ of lower order with an adequate passband and transition width is modulated throughout the spectrum for a set of bandpass filters covering the entire range of frequencies. All of these modulated versions are then interpolated by a factor L. The sum of interpolated even modulated channels and the sum of odd modulated channels plays the role of the $H_a(z^L)$ and $H_c(z^L)$ in traditional FRM [16]. The sum of interpolated even modulated channels is called even band-edge shaping filter bank (even BES-FB) and the sum of odd

modulated channels is called odd band-edge shaping filter bank (odd BES-FB). The number of modulations of the prototype filter has to be odd so that alternately they can be added to form the even and odd BES-FBs. Also, full spectral coverage by the prototype filter and its modulated versions is ensured by the condition:

$$(m + 1)(\rho + \varphi) = 2\pi \quad (3)$$

where ρ and φ denotes the passband and stopband edge frequencies of the prototype filter respectively. The number of modulated filters, m must be odd such that the frequency response occurs alternately when the modulated filters are recombined. Therefore,

$$m = 2p + 1; p = 0, 1, 2, \dots \quad (4)$$

Finally, the ModFRM filter is created by cascading the even BES-FB and odd BES-FB with the masking filters $H_{Ma}(z)$ and $H_{Mc}(z)$ respectively, as in Fig. 2.

The transfer function of the ModFRM filter can be expressed as [23]:

$$H(z) = [H_{a,0}(z^L) + H_{a,2}(z^L) + \dots + H_{a,2p}(z^L)]H_{Ma}(z) + [H_{a,1}(z^L) + H_{a,3}(z^L) + \dots + H_{a,2p+1}(z^L)]H_{Mc}(z) \quad (5)$$

where $H_{a,q}(z^L)$ is the q^{th} DFT modulated prototype filter interpolated by L . Equation (5) can be rewritten as:

$$H(z) = \sum_{i=0}^p H_{a,2i}(z^L)H_{Ma}(z) + \sum_{i=0}^p H_{a,2i+1}(z^L)H_{Mc}(z) \quad (6)$$

where,

$$\sum_{i=0}^p H_{a,2i}(z^L) \text{ represents the even BES - FB}$$

$$\sum_{i=0}^p H_{a,2i+1}(z^L) \text{ represents the odd BES - FB}$$

Both the even BES-FB or odd BES-FB can be used to determine the frequency response of the ModFRM filter around the transition band. Accordingly, the masking filter design may be done in two ways as follows [23]:

Case I

$$\omega_{p,Ma1} = \frac{3\rho+2\varphi}{L}; \omega_{s,Ma1} = \frac{4\rho+3\varphi}{L}; \quad (7)$$

$$\omega_{p,Mc1} = \frac{\rho+2\varphi}{L}; \omega_{s,Mc1} = \frac{2\rho+3\varphi}{L}; \quad (8)$$

Case II

$$\omega_{p,Ma2} = \frac{\varphi}{L}; \omega_{s,Ma2} = \frac{\rho+2\varphi}{L}; \quad (9)$$

$$\omega_{p,Mc2} = \frac{2\rho+\varphi}{L}; \omega_{s,Mc2} = \frac{3\rho+2\varphi}{L}; \quad (10)$$

For higher values of L , the masking filter's complexity is significant, as can be interpreted from (15). Therefore, the masking filters are built using the interpolated FIR (IFIR) method [4], a simpler counterpart of FRM used for designing narrow passband sharp filters. The IFIR structure comprises two filters: the IFIR modal filter and

the image-suppressor filter. For minimal multipliers, the optimal interpolation factor, L_{IFIR} , is determined as follows:

$$L_{IFIR} = \frac{2\pi}{\omega_{p,Ma} + \omega_{s,Ma} + \sqrt{2\pi(\omega_{s,Ma} - \omega_{p,Ma})}} \quad (11)$$

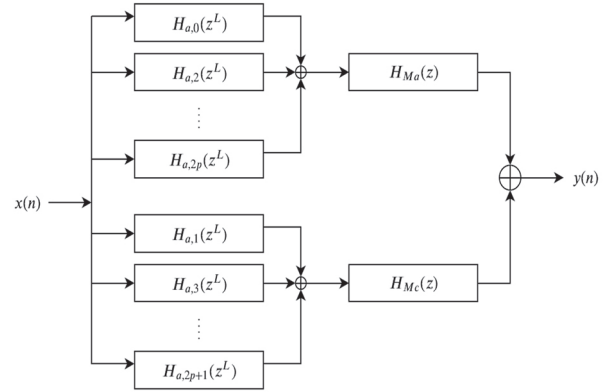

Fig. 2. Proposed ModFRM structure [23]

3.2 SPARSE ULA BEAMFORMER USING MODFRM TECHNIQUE

Assume we know the source is in a specific area between angles ϕ_1 and ϕ_2 . So, we intend to create a beamformer that receive signals from a range of ϕ_1 to ϕ_2 but attenuates signals from other directions. Mathematically, the directional response $B_d(\phi)$ is written as:

$$B_d(\phi) = \begin{cases} 1 & \text{if } \phi_1 \leq \phi \leq \phi_2 \\ 0 & \text{otherwise} \end{cases} \quad (12)$$

As the main lobe width reduces, the number of antenna elements increases, whereas the number of nulls keeps growing. This will suppress a significant proportion of interference, but the computational complexity of the beamformer shoots up drastically. In this work, a Modified FRM (ModFRM) architecture is suggested for designing hardware efficient sparse ULA beamformers having sharp beamwidth of better angular resolution. For the design of spatial filters, three attributes are required:

- 3-dB main beamwidth in the direction of ϕ_0 of the intended beamformer (and its associated 3-dB spatial frequency).
- Intended beamformer's null-to-null main beamwidth in the direction of ϕ_0 (and its associated null-to-null spatial frequency).
- The intended beamformer's SLL.

With the ModFRM technique, initially, a prototype beamformer is synthesized. It is then modulated and spatially interpolated by an appropriate expansion factor to increase the inter-element spacing. The even and odd modulated versions of the prototype beamformer that are spatially interpolated are subsequently grouped to constitute the two spatial shaping filters, namely, the even spatial shaping filter and the odd spatial shaping filter. To reduce grating lobes that appear due to changes in spacing, the beam pattern of spatial shaping filters is cascaded with the spatial masking fil-

ters (B_{Ma} and B_{Mc}) as in Fig. 2. If the masking beamformers are created using the IFIR approach, the antenna components will be reduced even further. This is because IFIR decomposes the design of a sharper beam pattern into the design of two spatial filters having beam patterns of broader beam width. These two spatial filters are modal beamformer and image-suppressor beamformer, respectively.

When compared to the traditional approach, the suggested method has the following merits:

- The aperture functions of the ULA beamformer formed with the ModFRM filter synthesis can provide a very narrow main beamwidth and low SLL.
- It can separate two closely spaced objects with minimal elements, resulting in a considerable decrease in the number of components utilized.
- The main beam width and the SLL can be specified individually without making a trade-off.

Table 1. FRM subfilter parameters for narrow beam ULA synthesis.

	FRM Subfilter	3-dB Beamwidth	3-dB Spatial frequency	Null-to-Null Beamwidth	Null-to-Null Spatial frequency	No: of Antenna Elements
1.	Prototype Beamformer	5.8°	0.1696	21°	0.3304	42
2.	Spatial masking filter, Ma	3°	0.0551	10.5°	0.1384	87
3.	Spatial masking filter, Mc	3°	0.1116	10.5°	0.1949	87

4. DESIGN EXAMPLE

A ULA beamformer with a 3-dB main beamwidth of 1 at direction 90° (3-dB spatial frequency is 0.1116), a null-to-null beamwidth of 3.5° (null-to-null spatial frequency is 0.1384) and the desired SLL of -60dB is taken as an example. In this work, the Dolph-Chebyshev model is a popular weighting method used for pattern synthesis [28, 29]. Using this model, uniformly spaced linear arrays oriented to broadside with specified SLL and null-null beam width can be established. The total number of elements for desired beamformer design using the direct-form FIR method is found to be 255. To design the desired beam pattern using conventional FRM structure, the 3-dB and null-to-null beamwidth required by the prototype beamformer and the spatial masking beamformer are given in Table 1. The FRM beamformer output is then given by Equation (13) [20].

$$y(n) = B_a(M\phi)B_{ma}(\phi) + B_c(M\phi)B_{mc}(\phi) \quad (13)$$

As seen from (13), the FRM beamformer is the sum of Here, M represents the spatial interpolation factor and $B_c(\phi)$ corresponds the complementary spatial filter of the prototype beamformer, $B_a(\phi)$. In this scenario, the prototype beamformer and the two spatial masking beamformers will require 216 antenna elements (42+87+87). Table 2 lists the frequency specifications for the various ModFRM subfilters and the corresponding number of antenna elements required for the proposed ModFRM beamformer synthesis. Thus, 157 antenna elements (25+49+18+49+16) are sufficient for attaining the intended beam pattern using the newly proposed ModFRM technique. Fig. 3 shows the prototype beamformer and Fig. 4 is the IFIR modal beamformer for the design of spatial masking beamformer, B_{Ma} . In Fig. 5, the modal beamformer of $B_{Ma}(\phi)$ is spatially interpolated and is masked with an image-suppressor

beamformer, according to the principle of the IFIR technique. Similarly, the modal beamformer and the image-suppressor beamformer of $B_{Mc}(\phi)$ are designed. Finally, the intended beamformer with a 3-dB main beamwidth of 1° and a null-to-null beamwidth of 3.5° is generated using Equation (5). The obtained ModFRM beamformer is given in Fig. 6.

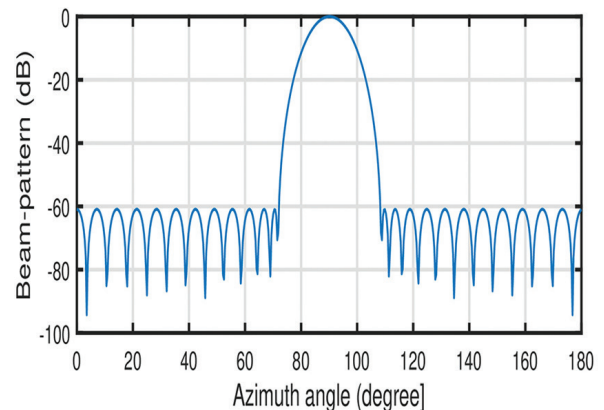

Fig. 3. Prototype Beamformer

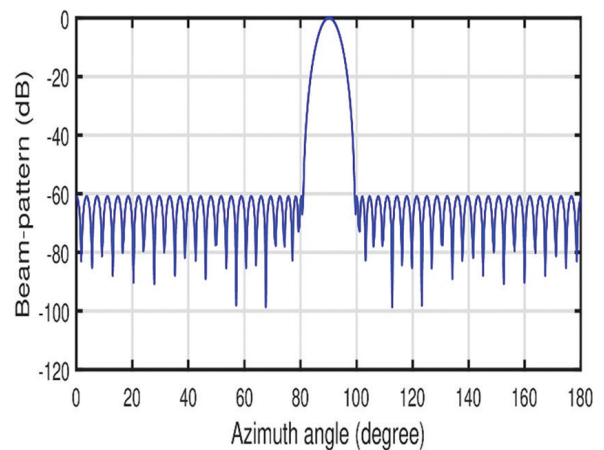

Fig. 4. Spatial modal filter of $H_{Ma}(z)$.

Table 2. ModFRM subfilter parameters for narrow beam ULA synthesis.

	ModFRM Subfilter	3-dB Beamwidth	3-dB Spatial frequency	Null-to-Null Beamwidth	Null-to-Null Spatial frequency	No: of Antenna Elements
1.	Prototype Beamformer	10°	0.1157	36°	0.3843	25
2.	Modal beamformer for spatial masking filter, B_{Ma}	5.4°	0.3348	18.4°	0.4848	49
3.	Image-suppressor beamformer for spatial masking filter, B_{Ma}	15°	0.1116	50°	0.5051	18
4.	Modal beamformer for spatial masking filter, B_{Mc}	5.4°	0.2652	18.4°	0.4152	49
5.	Image-suppressor beamformer for spatial masking filter, B_{Mc}	15°	0.0884	50°	0.5283	16

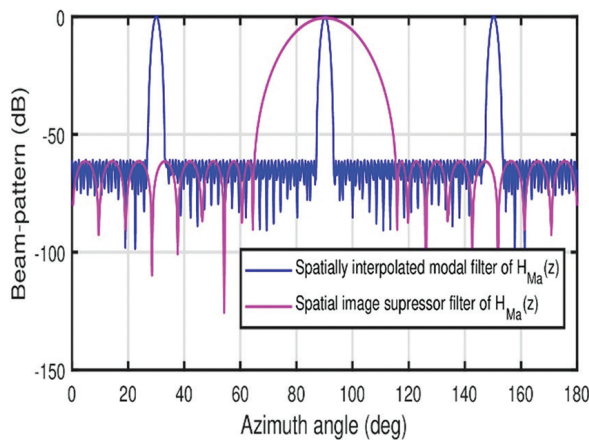

Fig. 5. Spatially interpolated modal filter and image-suppressor filter for $H_{Ma}(z)$.

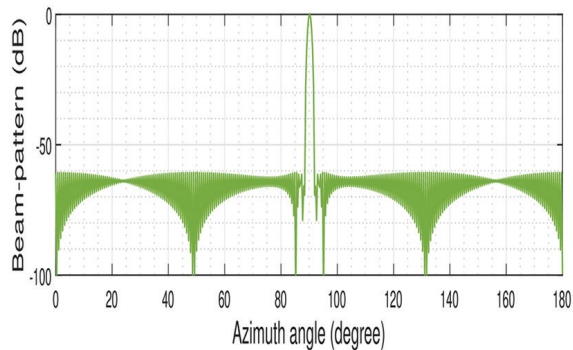

Fig. 6. ModFRM Beamformer

As an outcome, a beam pattern with a narrow main beamwidth (due to increased spacing) and low SLL (attributable to the attenuation of the spatial masking filter) is created without expanding the number of antenna elements. To put it another way, using a spatially interpolated beamformer allows one to lower the number of antenna elements while maintaining the same main beamwidth and SLL as the classic beamforming approach, which requires a more significant number of elements. Furthermore, because of the wider inter-element separation, mutual coupling amongst antenna elements can be reduced, which is an essential concern in practicality.

5. CONCLUSION

In this paper, a ModFRM-based narrowband beamforming architecture is introduced. With this technology, a beamformer may be designed to produce a sharp beam with low SLL that can point to specific cells and prevent inter-cell interference. Computer simulations demonstrate that the proposed beamformer provides a more directive main lobe with fewer sensor elements compared to the sparse array beamformer designed using conventional FRM technique. Hence, the suggested method may be used in a wide range of scenarios where a sharp beam with low sidelobe level is required, which otherwise demands a massive antenna array.

6. REFERENCES

- [1] N. Dey, A. S. Ashour, "Direction of arrival estimation and localization of multi-speech sources", Springer, 2018.
- [2] B. D. Van Veen, K. M. Buckley, "Beamforming: A versatile approach to spatial filtering". IEEE ASSP Magazine, Vol. 5, No. 2, 1988, pp. 4-24.
- [3] R. Kokila, K. Chithra, R. Dhillsha, "Wideband beamforming using modified farrow structure FIR filtering method for sonar applications". Proceedings of the International Symposium on Ocean Technology, 2019, pp. 21-28.
- [4] K. Schuler, W. Wiesbeck, "Tapering of multitransmit digital beamforming arrays". IEEE Transactions on Antennas and Propagation, Vol. 56, No. 7, 2008, pp. 2125-2127.
- [5] L. J. Gudino, S.N. Jagadeesha, J. X. Rodrigues, "A novel design of sharp transition fir filter for digital beamforming", Proceedings of the 6th International Symposium on Communication Systems, Networks and Digital Signal Processing, 2008, pp. 247-250.
- [6] L. J. Gudino, S.N. Jagadeesha, J. X. Rodrigues, "A novel filter design for spatially interpolated beamform-

- er”, Proceedings of the International Symposium on Intelligent Signal Processing and Communications Systems, 2009, pp. 1-4.
- [7] Y. Zhang et al, “Flat topped radiation pattern synthesis based on FIR filter concept”, Proceedings of the IEEE Asia Pacific Microwave Conference, 2017, pp. 751-754.
- [8] M. B. Hawes, W. Liu, “Sparse array design for wide-band beamforming with reduced complexity in tapped delay-lines”, IEEE/ACM Transactions on Audio, Speech, and Language Processing, Vol. 22, No. 8, 2014, pp. 1236-1247.
- [9] Z. Zheng, Y. Fu, W.-Q. Wang, “Sparse array beamforming design for coherently distributed sources”, IEEE Transactions on Antennas and Propagation, Vol. 69, No. 5, 2020, pp. 2628-2636.
- [10] Q. Lu et al. “Cognitive wideband beamforming for sparse array”, Proceedings of the IEEE Radar Conference, 2020, pp. 1-6.
- [11] S. A. Hamza, M. G. Amin, “Sparse array design for transmit beamforming”, Proceedings of the IEEE International Radar Conference, 2020, pp. 560-565.
- [12] M. Ruan, L. W. Hanlen, M. C. Reed, “Spatially interpolated beamforming using discrete prolate spheroidal sequences”, Proceedings of the IEEE International Conference on Acoustics Speech and Signal Processing Proceedings. Vol. 3, 2006.
- [13] T. Do-Hong, P. Russer, “A new design method for digital beamforming using spatial interpolation”, IEEE Antennas and Wire-less Propagation Letters, Vol. 2, 2003, pp. 177-181.
- [14] R. G. Pridham, R. A. Mucci, “Digital interpolation beamforming for low-pass and bandpass signals”, Proceedings of the IEEE, Vol. 67, No. 6, 1979, pp. 904-919.
- [15] C. Sun, Q.L. Guo, Y.X. Yang, “Design broadband beamformers via interpolation techniques”, OCEANS, 2007, pp. 1-4.
- [16] Y. Lim, “Frequency-response masking approach for the synthesis of sharp linear phase digital filters”, IEEE Transactions on Circuits and Systems, Vol. 33, No. 4, 1986, pp. 357-364.
- [17] Y. C. Lim et al, “FPGA implementation of digital filters synthesized using the FRM technique”, Circuits, Systems and Signal Processing, Vol. 22, No. 2, 2003, pp. 211-218.
- [18] Y. Neuvo, D. Cheng-Yu, S. Mitra, “Interpolated finite impulse response filters”, IEEE Transactions on Acoustics, Speech, and Signal Processing, Vol. 32, No. 3, 1984, pp. 563-570.
- [19] Y. Liu, Z. Lin, “On the applications of the frequency response masking technique in array beamforming”, Circuits, Systems and Signal Processing, Vol. 25, No. 2, 2006, pp. 201-224.
- [20] Y. Liu, Z. Lin, “Active array beamforming using the frequency-response masking technique”, Proceedings of the IEEE International Symposium on Circuits and Systems, Vol. 3, 2004.
- [21] P. P. Vaidyanathan, C.-C. Weng, “Active beamforming with interpolated FIR filtering”, Proceedings of the IEEE International Symposium on Circuits and Systems, 2010, pp. 173-176.
- [22] O. Rosen, I. Cohen, D. Malah, “FIR-based symmetrical acoustic beamformer with a constant beamwidth”, Signal Processing, Vol. 130, 2017, pp. 365-376.
- [23] A.K. Parvathi, V. Sakthivel, “Low complexity reconfigurable modified FRM architecture with full spectral utilization for efficient channelizers”, Engineering Science and Technology, Vol. 28, 2022, p. 101022.
- [24] W. Kellermann, “Beamforming for speech and audio signals”, Handbook of Signal Processing in Acoustics, Springer, 2008, pp. 691-702.
- [25] H. L. Van Trees, “Optimum array processing: Part IV of detection, estimation, and modulation theory”, John Wiley & Sons, 2004.
- [26] J. G. Ryan, R. A. Goubran, “Array optimization applied in the near field of a microphone array”, IEEE Transactions on speech and Audio Processing, Vol. 8, No. 2, 2000, pp. 173-176.
- [27] L. C. Godara, “Application of antenna arrays to mobile communications. II. Beam-forming and direction-of-arrival considerations”, Proceedings of the IEEE, Vol. 85, No. 8, 1997, pp. 1195-1245.
- [28] R.C. Hansen, “Dolph-Chebyshev array directivity against spacing”, Electronics Letters, Vol. 32, No. 12, 1996, pp. 1050-1051.
- [29] N. Fadlallah et al. “Antenna array synthesis with Dolph-Chebyshev method”, Argument, Vol. 2, 2011, p. 3