

The Use of NS-2 Simulator in Studying UMTS Performances

Preliminary Communication

Mario Vranješ

Faculty of Electrical Engineering
Josip Juraj Strossmayer University of Osijek, Croatia
mario.vranjes@etfos.hr

Tomislav Švedek

Faculty of Electrical Engineering
Josip Juraj Strossmayer University of Osijek, Croatia
tomislav.svedek@etfos.hr

Snježana Rimac-Drlje

Faculty of Electrical Engineering
Josip Juraj Strossmayer University of Osijek, Croatia
rimac@etfos.hr

Abstract – Universal Mobile Telecommunication System (UMTS) is a third-generation mobile communications system that supports high bit rate wireless multimedia applications. In addition to UMTS, HSDPA-based UMTS networks improve the initial UMTS networks in terms of radio resource allocation and data transfer performances. Due to the complexity of such system and difficulty of access to the real system, it is very important to have a reliable simulation tool for performance evaluation and development of new solutions. In this paper, a module for end-to-end UMTS HSDPA-based simulation for QoS evaluation is used. The Enhanced UMTS Radio Access Network Extensions (EURANE) provided UMTS and HSDPA support in the Network Simulator (NS-2). The simulator can evaluate parameters associated with Enhanced UMTS performance (end-to-end delay, jitter, throughput) to assess the impact of new protocols and architectures. Performance evaluation conducted in this paper captures the performance of the air interface for mobile users moving through different environments.

Keywords: EURANE, HSDPA, NS-2, QoS, UMTS

1. INTRODUCTION

In modern communication systems an increasing number of services are provided by using wireless technologies. The Universal Mobile Telecommunications System (UMTS) is one of the 3rd Generation (3G) mobile systems whose main purpose is to offer a universal infrastructure which is able to deliver both existing and future services. 3G is standardized by a worldwide 3G Partnership Projects (3GPP in Europe and 3GPP2 in USA) [1], [2]. 3G wireless networks are developed to carry multimedia traffic such as voice, mixed voice and data, image and video transmission, web request, email and other application. Since the requirements for new wireless services and their data rates increase, 3GPP has developed High Speed Downlink Packet Ac-

cess (HSDPA), in order to improve the support of high data rate packet services. HSDPA is considered 3.5G offering data rates up to 14 Mbps [3].

An Enhanced UMTS network is an All-IP based network that will support additions and modifications to the UMTS network [4]. Since the new services require more resources, these modifications aim to satisfy the need for a capacity increase in the access network, flexibility in the core network and support supplementary integrated services that the standardized UMTS network is not expected to provide. Because of that, Enhanced UMTS is a UMTS evolution step which makes an effective end-to-end packet-based transmission possible [5].

The Network Simulator (NS-2) is a discrete, event-driven network simulator [6] developed initially at UC Berkeley and later supported by the Virtual InterNetwork Testbed (VINT) project [7]. Since the 3G sys

These materials are based on the work financed by The National Foundation for Science, Higher Education and Technological Development of the Republic of Croatia.

tems such as UMTS and HSDPA were not part of the mainstream code, in [8] a general implementation of UMTS and HSDPA functionalities in NS-2 is provided. Recently there has been a growing interest in research of the UMTS performances by using different simulation models in NS-2. The performances of different Radio Link Control (RLC) modes are compared by using different multimedia services for UMTS [9]. In [3], the radio resource and scheduling optimization in HSDPA based UMTS networks is proposed, while the performance evaluation of an Enhanced UMTS network in a business city centre environment is presented in [5]. Additionally, the performance evaluation of MPEG-4 video streaming over UMTS Networks is analyzed in [10] and [11].

This paper gives simulation results of an Enhanced UMTS mobile network which implements HSDPA and examines its behavior by measuring network performances (jitter, end-to-end delay, instant throughput) for mobile users located in different environment types and at different distances from the base station. Also, the speed of mobile users was variable. The aim of this paper is to show how different parameters influence the overall network performances and how the NS-2 testbed can be used for the Enhanced UMTS system performances evaluation. This simulation is made by using an NS-2 version 2.29 and the additional patch for Enhanced UMTS Radio Access Network Extensions (EURANE) for NS-2, [8], developed by SEACORN (Simulation of Enhanced UMTS Access and Core Network).

The paper is structured as follows. Section 2 gives an UMTS and HSDPA overview and Section 3 presents the main features of the NS-2 simulator and EURANE extension. Simulation results are presented in Section 4 and conclusions are given in Section 5.

2. UMTS

UMTS is a 3G mobile communication system where the radio interface is based on Wideband Code Division Multiple Access (WCDMA). Radio frequencies allocated for UMTS are 1900-2025 MHz and 2110-2200 MHz [12]. UMTS is among the first 3G mobile systems which offers wireless wideband multimedia communications over the Internet Protocol (IP) and as such, it allows mobile Internet users to access a variety of multimedia contents available on the Internet in a seamless fashion at data rates up to 2 Mbps indoor and 384 Kbps outdoor [12].

2.1. UMTS ARCHITECTURE

The UMTS system utilizes the same well-known architecture that has been used by all main 2G systems. Figure 1 shows a simplified architecture of UMTS for packet-switched operation [4]. It is composed of a number of logical network elements with defined functionalities. These network elements are grouped into: (1) the UMTS Terrestrial Radio Access Network (UTRAN), that

handles all radio related functionality, (2) the Core Network (CN), which is responsible for switching/routing calls and data connections to external networks, and (3) the User Equipment (UE), that interfaces with user applications and the radio interface.

The UTRAN is composed of Node Bs connected (via an Iub interface) to a Radio Network Controller (RNC). Note that a more generic term for the Node B is a base station (BS). The CN, which is the backbone of UMTS, encompasses the Serving GPRS Support Node (SGSN) and the Gateway GPRS Support Node (GGSN). UE, which is a mobile station, is connected to the Node B over the UMTS radio interface. More information about the function of these elements can be found in [4].

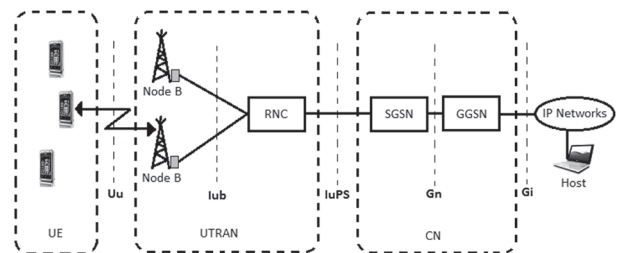

Fig. 1. UMTS Reference Architecture [4]

The UMTS protocol architecture which provides the transmission of user data (generated by IP-based applications) and its associated signaling is shown in Figure 2 [11]. The applications and the Internet protocol suite are located at the end-nodes (UE and host). Three different operating modes are possible at Radio Link Control (RLC): Acknowledged Mode (AM), Unacknowledged Mode (UM) and Transparent Mode (TM). The AM provides reliable data transfer over the error prone radio interface, while UM and TM do not guarantee data delivery. The Medium Access Control (MAC) layer can operate in either dedicated or common mode. In the dedicated mode, dedicated physical channels are allocated and used exclusively by one user (or UE), whereas in the common mode users share common physical channels for transmitting and receiving data [11]. Besides all radio frequency functionalities, as well as spreading and signal processing, the Physical layer (PHY) contains power control, forward error correction and interleaving.

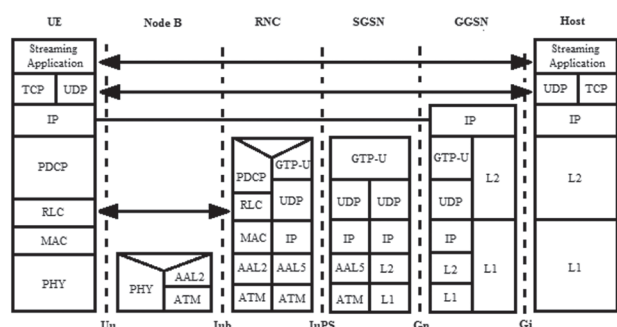

Fig. 2. UMTS Protocol Architecture [11]

2.2. HSDPA

HSDPA in UMTS enables users in the UMTS network to receive multimedia data with a high bit rate (up to 14 Mbps). It uses a shared-channel for data transmission (in time domain) and enables the possibility to rapidly allocate a large amount of downlink resources when required. The basic techniques used in HSDPA are [3]:

(1) Adaptive Modulation and Coding (AMC) – The most important technique is the fast link adaptation provided by the use of AMC. It consists of the constant power Node B transmission while the Modulation and Coding Scheme (MCS) is altered to adapt to channel variations.

(2) Hybrid Automatic Repeat Request (HARQ) – Under normal circumstances, approximately 10 – 30 % of first transmissions must be resent to be successful [3]. In order to decrease the round-trip time for retransmissions, the retransmissions are done from the base station instead of the radio network. If retransmission is needed, the user device saves an incorrect packet and combines it later with a retransmitted packet to recover the error-free packet as efficiently as possible.

(3) Fast scheduling – The allocation of radio resources to separate users is an important issue, and it is known as the scheduling strategy. In HSDPA the scheduler is located at the Node B enabling the scheduler to respond quickly to the changes of channel conditions. A different type of schedulers can be implemented, like Round Robin (RR), Maximum C/I and Fair Channel-Dependent Scheduling (FCDS), whose main characteristics are presented in Figure 3 [4]. More information about these scheduling strategies can be found in [4].

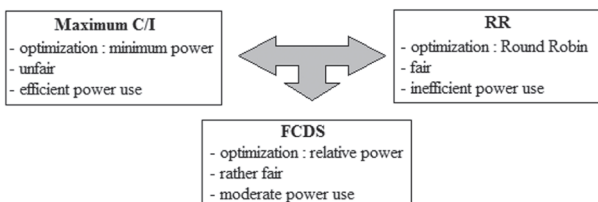

Fig. 3. Scheduling methods [4]

3. NETWORK SIMULATOR AND EURANE EXTENSION

NS-2 is an object-oriented network simulator written in C++ and OTcl. As an open source software, numerous extensions have been added to NS-2, thus making it a popular simulation tool for advanced network research. Although NS-2 provides extensive support for wireless ad-hoc networks and satellite links, 3G systems such as UMTS and HSDPA were not part of the mainstream code. Several contributed modules implement UMTS functionality in NS-2 with varying levels of details. The most notable extension is EURANE and this is the reason why it is used in this paper.

EURANE adds three nodes to NS-2, namely RNC, Node B (BS) and UE. Additionally, in EURANE most of

the protocol architecture is implemented between the UE and the fixed host on the Internet. The main protocol additions to NS-2 are the RLC modes (AM and UM) as well as MAC-d and MAC-c/sh support for different transport channels. Figure 4. shows the overall model of HSDPA protocol architecture [4].

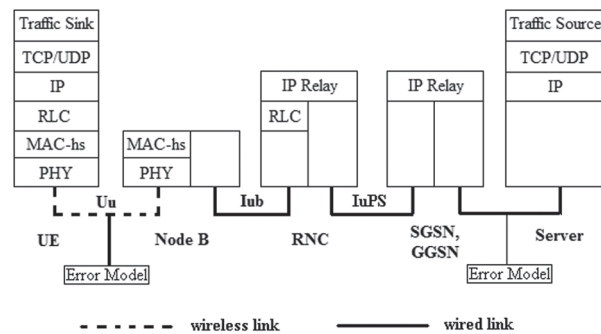

Fig. 4. Simulation protocol architecture model [4]

In this chapter the portion of EURANE that implements HSDPA functionality is discussed. Three layers are contributed by EURANE [13], [14]. The first layer is the RLC layer. It exists at the RNC and UE. The second layer is the MAC layer which can be split into two sub-layers: the MAC-d, which exists at the RNC and UE and the MAC-hs, which exists at Node B. At the bottom of the stack is the physical layer (PHY) which exists at the Node B and the UE. These layers implement most of the functions defined in 3GPP Release 5 [15]. In the AM mode these functions are: segmentation and reassembly, padding and concatenation, in-sequence delivery, window-based flow control, retransmissions and duplicate Protocol Data Units (PDU) detection. The basic operation of AM, as well as UM, can be found in [14].

At the MAC layer, the MAC-d is abstracted and it only provides channel switching between dedicated (DCH) and shared (FACH) channels. The MAC-hs is the layer responsible for HSDPA, and its model implements the two main features of HSDPA: fast scheduling and HARQ. The fast scheduler is informed about channel conditions through Channel Quality Indicator (CQI) feedback reports received from UEs. In every time slot (2 ms) the scheduler scans all priority queues and, according to feedback information, selects the candidate queue for the next transmission slot. Selection of the transmission rate is done by using 3GPP's tabulated Transport Format and Resource Combinations (TFRC) and CQI. Once a user is scheduled, the MAC-hs creates a MAC-hs PDU, or a transport block, containing multiple MAC-d PDUs, and assigns it to a HARQ process. The HARQ process persists on the block transmitting to the UE until it receives an acknowledgement or reaches the maximum number of retransmissions. The physical channel model uses the HARQ scheme with Acknowledgements (ACK) and CQI. The amount of data transmitted in the MAC-hs frame is determined based on the CQI value. After reception, an ACK or NACK (Negative

ACK) is generated depending on the received Signal to Noise Ratio (SNR) value and a maximum Block Error Rate (BLER) of 10 %. The SNR values are pre-computed for each UE using MATLAB script that generates signal samples dependent on distance loss, shadowing, multi-path and interference, according to the given channel model.

The channel model parameters depend on the environment. The loss is defined as follows [4]:

$$L=A+S+R, \quad (1)$$

where A is the attenuation (path loss), S is slow fading (shadowing) and R is fast fading (multi-path fading). The attenuation is described by the Okumura-Hata propagation reference model for suburban areas:

$$A(d)=L_{init}+10 \cdot n \cdot \log_{10}(d), \quad (2)$$

where d is the distance between the Node B and the UE in kilometers, L_{init} is the basic loss at a 1 km distance and n is the decay index. L_{init} and n depend on the environment. In most practical cases n is between 2 and 4. The channel model in EURANE is designed for the purpose of studying the effect of scheduling on nearby vs. far away users and hence the distance of each UE from the BS is assumed fixed, i.e. users move circularly around the base station. According to this, the distance loss remains constant throughout the simulation time.

Slow fading is caused by large obstacles in the propagation path between the UE and the Node B. It is modeled as a process with a lognormal distribution. In a dynamic model with mobile users slow fading is dependent on the location and thus the location dependent correlation must be accounted for in order to provide continuity. This study includes a correlation model for slow fading developed in [16]. The correlated slow fading contribution to the total loss is constructed from the following algorithm:

$$S(d+\Delta d)=a \cdot S(d)+b \cdot \tilde{\sigma} \cdot N, \quad (3)$$

where Δd is the distance between two subsequent time samples and N is a random variable that satisfies the standard normal distribution. The parameter b is usually taken such that the standard deviation of the vector containing all realizations equals $\tilde{\sigma}$, while the parameter a is determined by the following demand which concerns the autocorrelation function of S :

$$E[S(d) \cdot S(d+\Delta d)] = E[a \cdot (S(d))^2 + b \cdot \tilde{\sigma} \cdot N] = a \cdot \tilde{\sigma}^2 \quad (4)$$

This expression should be equal to $\exp(-\Delta d/D) \cdot \tilde{\sigma}^2$ and it results in the demand that $a=\exp(-\Delta d/D)$, where D is the correlation distance.

The multi-path, or fast fading R , is modeled by using various International Telecommunication Union – Telecommunication standardization sector (ITU-T) channel profiles. Thirteen channel profiles are implemented

in EURANE: *Single Rayleigh channel, three Single Rayleigh channels w/o correlation on fading coefficients – Case 1, Case 2 and Case 3, Indoor Office A, Indoor Office B, Pedestrian A, Pedestrian B, Vehicular A, Vehicular B, Rural Area, Typical Urban and Hilly Terrain*. The profiles differ in respect to the number of paths as well as delays and the average power of the rays. Finally, both intra-cell and inter-cell interference are assumed constant throughout the cell area [4], [14]. The intra-cell interference is added at the input of the channel model, while the inter-cell interference is added at the input of the receiver.

To implement the physical layer, the standard NS-2 channel object is used to connect the BS to the UEs. The channels use the standard NS-2 error model which provides a simple probabilistic packet loss. However, for HSDPA a more realistic error model is required to take into account the long- and short-term variations in link quality in order to model the fast link adaptation, fast scheduling and HARQ. Therefore, EURANE uses a pre-computed BLER/SNR performance curve and input trace file of received powers (expressed in SNR) to generate the required error model for HSDPA. The input trace file is generated for each UE according to the physical channel model. This file contains SNR values of the first, second and third transmission attempts in addition to the CQI in each time slot (2 ms) [13]. The files are then attached to the corresponding flow in NS-2 using the simulation script. The *Mac/Hsdpa* object in the Node B loads all the files into a memory data structure before the simulation starts. After that, the SNR and CQI values are read on demand by different class methods such as the scheduler and HARQ. For the SNR/BLER curve, a single file provides mapping between a certain BLER range and the minimum SNR value required for a specific CQI. This file is also loaded into memory to be used by the receivers *HsdpaPhy* object to determine whether an ACK or NACK should be generated for the received SNR [14].

4. SIMULATION RESULTS AND DISCUSSION

In this section simulation results obtained by using the NS-2 simulator with EURANE extensions are presented. The simulation topology consists of a single cell with the BS connected to the RNC. Two nodes represent the SGSN and GGSN while another two nodes represent external IP networks, to model a communication path between a mobile user and a fixed communication node (node 2). The simulations are performed for ten mobile users (UE1 – UE10). The topology is shown in Figure 5.

Since the primary aim of the simulation was to examine the impact of the radio interface on data transmission, it is assumed that no packet losses, errors or congestion occur on either the Internet or the UMTS network. The transfer delay introduced by the Internet and the UMTS core network is constant throughout the entire data transmission duration. The links be

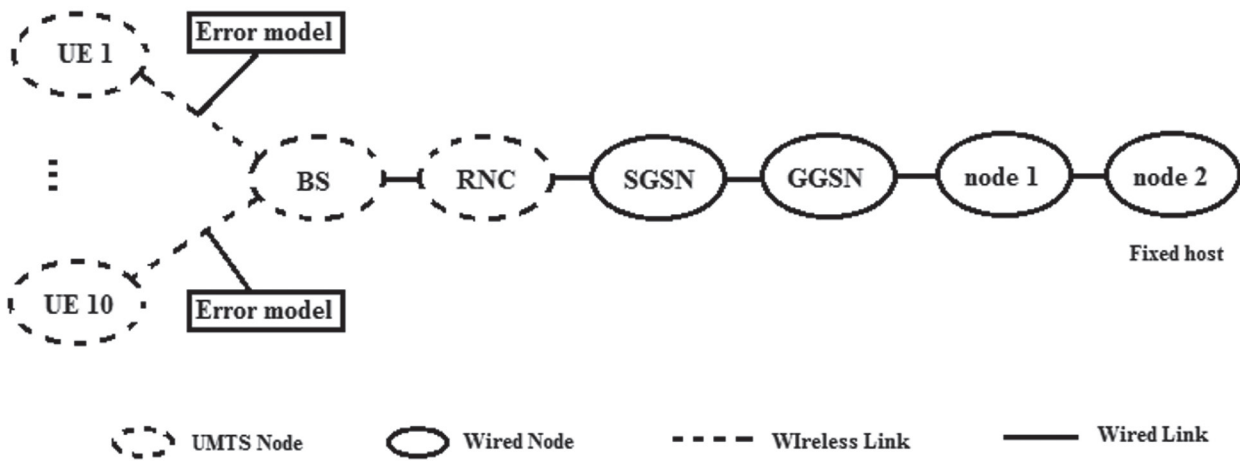

Fig. 5. The single cell simulation topology

tween two nodes are labeled with their bit rates and delays. The links' characteristics (bandwidth and delay) are summarized in Table 1. Only performances of the radio interface between the BS and mobile nodes are examined. Mobile users are considered as pedestrians or vehicles (depending on the environment type) moving at equal distances from the base station (circular movement).

Table 1. Links' characteristics

Link	Bandwidth (Mbps)	Delay (ms)
node 2 – node 1	100	35
node 1 – GGSN	100	15
GGSN – SGSN	622	10
SGSN – RNC	622	0.4
RNC – BS (uplink)	622	15
RNC – BS (downlink)	622	15

Additional assumptions have been done: each mobile node runs one service and each mobile node runs the same service, UDP based Constant Bit Rate (CBR) traffic (bit rate 128 Kbps, packet size 1000 bytes), from the beginning of the simulation until the end of the simulation. All data flows had the same priority, while the scheduling mechanism was set to Maximum C/I. The simulation time was 10 seconds in both simulations conducted and the AM mode at RLC is used in order to examine its performances. According to [11], AM is superior to UM for a CBR traffic type (due to the HARQ process) and this is the reason why the AM mode is chosen in our simulations.

Simulations are initiated by generating user input matrices based on each desired environment using EURANE Matlab files [8] on Matlab 7.1. The matrices are useful to represent the error model of each user environment. As mentioned above, two simulations are performed, one for Pedestrian A environment and one for Rural environment from EURANE. The tapped-

delay-line parameters for each environment are presented in Table 2 [8].

Table 2. The tapped-delay-line parameters for each environment [8]

Tap	Pedestrian A		Rural	
	Relative delay [ns]	Average power [dB]	Relative delay [ns]	Average power [dB]
1	0	0	0	0
2	110	-9.7	42	-1.2
3	190	-19.2	101	-3.2
4	410	-22.8	129	-4.1
5	-	-	149	-4.8
6	-	-	245	-7.9
7	-	-	312	-10.1
8	-	-	410	-13.3
9	-	-	469	-15.2
10	-	-	528	-17.2

Users speed and distance from the BS were variable in both simulations and they are described in next sub-sections. Physical channel parameters are identical to the settings in the original Matlab script for EURANE physical layer simulations, and they are presented in Table 3.

Table 3. Physical channel settings [8]

Carrier frequency	2000 MHz
Base station transmission power	38 dBm
Base station antenna gain	17 dBi
Base station antenna height	30 m
UE antenna height	1.5 m
Initial loss at 1 km	137.4 dB
Path loss exponent	3.52
Intra-cell interference	30 dBm
Inter-cell interference	-70 dBm
Shadowing correlation distance	40 m
Standard deviation for shadow fading	8 dB

Simulation results were obtained by tracing all packets through a wireless link from the BS to different mobile users. Raw data was collected in a trace file, which in turn was manipulated using additional analysis scripts [18], [19], in order to extract information about jitter, end-to-end delay and instant throughput (for the link BS-UE).

4.1. PEDESTRIAN A ENVIRONMENT

In this simulation scenario ten HSDPA mobile users are located in a single cell (Pedestrian A environment [8]) at different distances from the BS. These distances for each user are presented in Table 4. Since all users are assumed to be pedestrians, their speed was the same and it was set to 3 km/h. Due to clarity of diagrams, 3 different mobile users are chosen (UE1, UE6, UE10) and their results for end-to-end delay (Figure 6.), jitter (Figure 7.) and instant throughput (Figure 8.) are compared.

Table 4. Simulation results for Pedestrian A environment

User	Distance from BS [m]	Average end-to-end delay [ms]	Average jitter [μ s]	Average instant throughput [Kbps]
UE1	50	2.6	0.503	144.4
UE2	100	7.1	0.506	48.4
UE3	150	12.0	3.05	28.7
UE4	200	16.8	-6.91	20.3
UE5	250	23.6	12.2	15.0
UE6	300	32.4	66.0	11.8
UE7	350	67.6	81.4	9.1
UE8	400	75.8	101.0	7.7
UE9	450	120.3	380.0	6.6
UE10	500	153.0	255.0	5.8

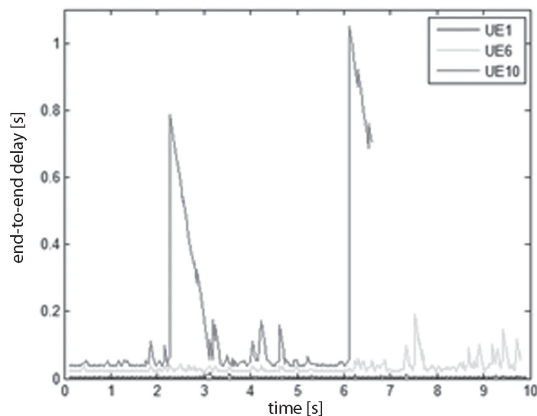

Fig. 6. End-to-end delay for Pedestrian A environment

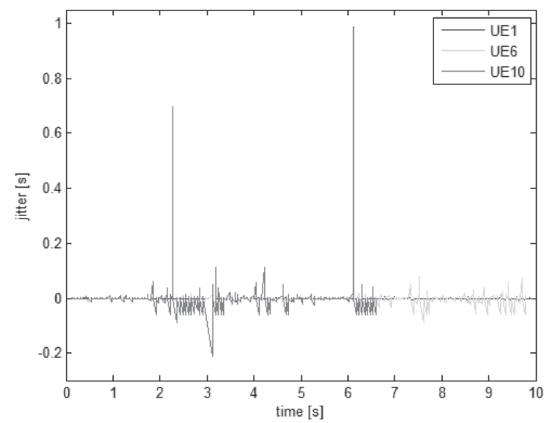

Fig. 7. Jitter for Pedestrian A environment

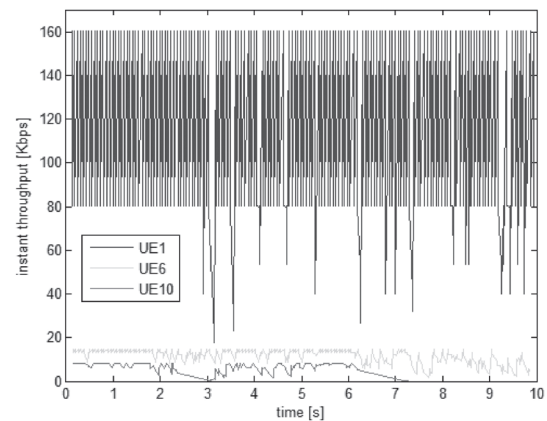

Fig. 8. Instant throughput for Pedestrian A environment

As shown in Figure 6., the shortest end-to-end delay is present for mobile user UE1 located 50 m from BS. When the distance from the BS increases, the end-to-end delay, as well as jitter, significantly rises. This is especially emphasized for the user that is very far from BS (UE10). The average end-to-end delay and the average jitter for all users are shown in Table 4. The opposite situation is with instant throughput. The user that is closest to the BS has the highest instant throughput value throughout the whole simulation time, while the farthest user has the smallest instant throughput which even falls to zero after the seventh second. The reasons for a such results can be found in facts that the traffic intended to UE1 passes the shortest path (having the smallest path loss) and that the scheduling mechanism (Maximum C/I) allocates the largest amount of radio resources to those users whose channel conditions (C/I, i.e. SNR) are best in the moment of sending. Hence, when the user's distance from the BS rises, the channel conditions become worse and the amount of radio resources allocated to this user is smaller. As can be seen, the end-to-end delay for user UE10 in one moment exceeds the border of 1 second. The reason for such a large delay is also more often requirements for retransmission (due to bad channel conditions), sometimes even multiple. The retransmitted packets are then received but with a significantly increased end-to-end

delay and jitter. Also, it can be seen from Figure 7 that the UE10 received the last packet about the seventh second and after that moment it did not receive any packet during the simulation time of 10 s.

4.2. RURAL ENVIRONMENT

The second simulation scenario deals with ten HS-DPA mobile users (UE1 – UE10) located in the same cell, but now all the users were in *Rural* environment [8]. The user speed and distance from the BS are shown in Table 5. Some examples of rural environment are open roadways and highways and thus the user speed in this experiment is higher in comparison to those in *Pedestrian A* environment. Also, in rural areas the cell radius is higher in comparison to those in typical pedestrian areas, and thus the distance from the BS varies up to 900 m in this experiment. We combined two different speed values with five different distance values in order to examine the impact of both parameters on radio resource allocation and data transfer performances. Simulation results for all users are presented in Table 5. Since the aim was to show a comparison regarding user speed and distance from the BS, four different users UE1, UE5, UE6, UE10 are chosen (due to clarity of diagrams) and their results for end-to-end delay, jitter and instant throughput are shown in Figure 9., Figure 10. and Figure 11., respectively. Similarly to the results for *Pedestrian A* environment, the greatest amount of radio resources is allocated to those users closer to the BS (the reasons are in generally the same as in the previous scenario). Thus their end-to-end delay and jitter are the smallest, while the instant throughput is the greatest throughout the whole simulation time. However, if the results for the users at the same distance from the BS but with different movement speed (UE3 and UE8) are compared, it can be seen that better performances (in terms of delay, jitter and instant throughput) are obtained for those users that move slower.

Table 5. Simulation results for Rural environment

User	Speed [km/h]	Distance from BS [m]	Average end-to-end delay [ms]	Average jitter [μ s]	Average instant throughput [Kbps]
UE1	50	100	4.1	1.0	114.6
UE2	50	300	22.0	-1.0	19.6
UE3	50	500	156.0	-1.7	8.2
UE4	50	700	824.2	-53.5	3.5
UE5	50	900	1618.7	-6600.0	3.5
UE6	150	100	8.7	-1.5	49.9
UE7	150	300	32.9	-2.0	15.9
UE8	150	500	236.3	-14.4	7.3
UE9	150	700	619.4	-177.0	2.6
UE10	150	900	1770.2	-6300.0	1.3

It can be concluded that the user speed plays a significant role in such type of the system. The exceptions are users that are very far from the BS (> 500 m). In this situation, simulation results show that the user speed does not play such an important role because the distance from the BS is too large and losses are too high (i.e. SNR is too small) for a successful data transfer, regardless of the user speed. Also, due to a large distance from the BS, multiple HARQ processes are required causing such a big delay and jitter at UE5 and UE10 in comparison to other users. Hence, with the increase of the distance from the BS, the impact of the user speed on data transfer performances decreases.

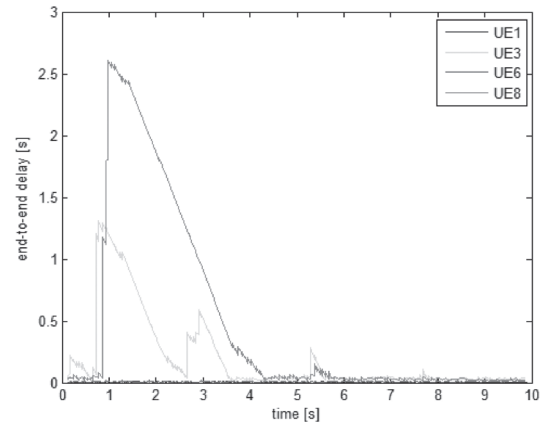

Fig. 9. End-to-end delay for *Rural* environment

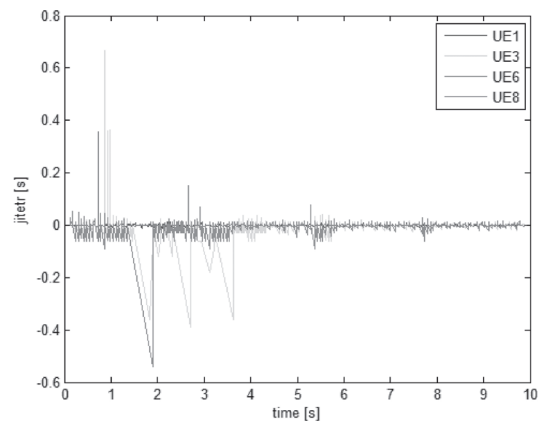

Fig. 10. Jitter for *Rural* environment

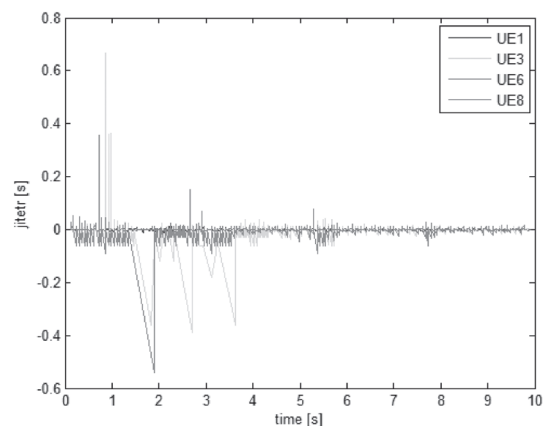

Fig. 11. Instant throughput for *Rural* environment

At the end of this analysis, two different environments can be compared. The UE2 in *Pedestrian A* environment and UE1 and UE6 in *Rural* environment are located at the same distances from the BS, i.e. at 100 m. Also, the UE10 in *Pedestrian A* environment as well as UE3 and UE8 in *Rural* environment are located at the distance of 500 m from the BS. Results presented in Tables 4 and 5 show that the performances are better for *Rural* environment, although mobile users in *Pedestrian A* environment move with a low speed (3 km/h).

5. CONCLUSION

This paper presents an NS-2 simulation environment for performance evaluation of Enhanced UMTS. Major extensions of NS-2 were developed to implement all the UMTS-aware nodes, the expected traffic types, topology and mobility scenarios. In this paper, EURANE patch for NS-2 is used for the purpose of examining the behavior of the system when more users in the same cell run constant bit rate traffic in the same time.

Based on simulation results and analysis, it can be concluded that a larger amount of radio resources is allocated to those mobile users that are closer to the BS. As the distance from the BS increases, the amount of allocated radio resources falls (according to the C/I scheduling mechanism). As a consequence of such scheduling mechanism, data transfer performances for closer users are better than for farther users. It can also be concluded that for the users that are close to the BS, the user speed has a significant impact on data transfer performances, while for very far users the losses are quite high and thus there is no big difference whether the user moves slowly or fast. Due to the usage of the AM mode at RLC (HARQ process), end-to-end delay and jitter are very high in some situations, but however, the packets are finally received at the end. Thus AM is used in applications requiring reliability, and UM is used in applications where smallest possible end-to-end delay has a priority, and requirements for reliability are not so high.

Since the access to the real system is often not possible and the investigation of such a complex system is in reality quite complicated, the model provides a simplified way of testing the effects of various parameters on the overall system performance. It is very important since such a model can be applied in the classroom, where, by changing the values of parameters, the behavior of the system in different situations and with different settings can be analyzed.

Since this paper describes only single cell environment situations, with users that move circularly around the base station and run the same type of service, future research will be conducted for system behavior in a multi-cell environment with handover possibilities. Also, more common situations when users run a different type of applications and can move in all directions will be examined. Furthermore, different scheduling mechanisms like RR or FCDS can be used in future works.

ACKNOWLEDGEMENT

This work was supported by research project grant No. 165-0361630-1636 from the Ministry of Science, Education and Sports of the Republic of Croatia.

REFERENCES

- [1] 3rd generation Partnership Project, <http://www.3gpp.org>, August 2010.
- [2] 3rd generation Partnership Project 2, <http://www.3gpp2.org>, August 2010.
- [3] A. Masmoudi, D. Zeghlache, S. Tabbane, Resource and Scheduling Optimizations in HSDPA Based UMTS Networks, 6th World Wireless Congress, May 24-27, 2005, San Francisco, USA, http://www.supcom.mincom.tn/mediatron/articles/WWC_2005.pdf, October 2010.
- [4] Deliverable D3. 2v2, End-to-end network model for Enhanced UMTS, <http://eurane.ti-wmc.nl/eurane/D32v2Seacorn.pdf.gz>, August 2010.
- [5] J. Antoniou, V. Vassiliou, A. Pitsillides, G. Hadjipollas, N. Jacovides, A Simulation Environment for Enhanced UMTS Performance Evaluation, <http://citeseerx.ist.psu.edu/viewdoc/summary?doi=10.1.1.10.5877>, August 2010.
- [6] The Network Simulator, NS-2, <http://www.isi.edu/nsnam/ns>, June 2010.
- [7] Virtual InterNetwork Testbed, <http://www.isi.edu/nsnam/vint/>, June 2010.
- [8] Enhanced UMTS Radio Access Network Extensions for NS2, <http://eurane.ti-wmc.nl/eurane/>, June 2010.
- [9] R. F. Sari, P. D. Purnamasari, F. Zaini, A. D. Gultom, Performance Evaluation of IP Based Multimedia Services in UMTS, *Revista Informatica Economica*, No. 3/47, 2008, pp. 6-11.
- [10] A. Panchaem, S. Kamolpiwong, M. Unhawiwat, S. Seawong, Evaluation of UMTS RLC Parameters for MPEG-4 Video Streaming, *ECTI Trans. on Computer and Information Technology*, Vol. 3, No. 1, 2007, pp. 56-62.
- [11] A. Lo, G. Heijen, I. Niemegeers, Performance Evaluation of MPEG-4 Video Streaming over UMTS Networks Using an Integrated Tool Environment, *Proc. of 2005 Int. Symp. on Performance Evaluation*

of Computer and Telecommunication Systems, Philadelphia, PA, USA, July 24-28 2005, pp. 676-682.

- [12] A. F. Molisch, *Wireless Communications*, John Wiley and Sons Ltd., Chichester, England, 2005.
- [13] EURANE User Guide (release 1.6), http://eurane.ti-wmc.nl/eurane/eurane_user_guide_1_6.pdf, June 2010.
- [14] A.M. Mutairi, U.A. Baroudi, NS-2 Enhancements for Detailed HSDPA Simulations, 2nd Int. Workshop on NS2, 3rd Int. Conf. on Performance Evaluation Methodologies and Tools, Athens, Greece, Oct. 24, 2008, Article No. 72.
- [15] 3GPP TS 25.308 "High Speed Downlink Packet Access; Overall Description; stage 2 (Release 5)" v7.3.0, June 2007.
- [16] M. Gudmundson, Correlation model for shadow fading in mobile radio systems, *Electronics Letters*, Vol. 27, No. 23, 1991, pp. 2145-2146.
- [17] W. C. Jakes, *Microwave Mobile Communications*, Wiley, New York, 1974.
- [18] L. Balliache, Flows: how they compete for network resources, <http://www.opalsoft.net/qos/Flows.htm>, July 2010.
- [19] K. Chin-Heng, How to measure packet loss rate, jitter, and end-to-end delay for UDP-based applications?, http://hpds.ee.ncku.edu.tw/~smallko/ns2/tool_en.htm, August 2010.